

POR CARNE HUMANA RANCHO  
POR. LOT 33 KILBURN HOMESTEAD TRACT  
POR. LOT 5 SEC 7, T.8N., R.6W., M.D.B&M.

Tax Area Code  
55000

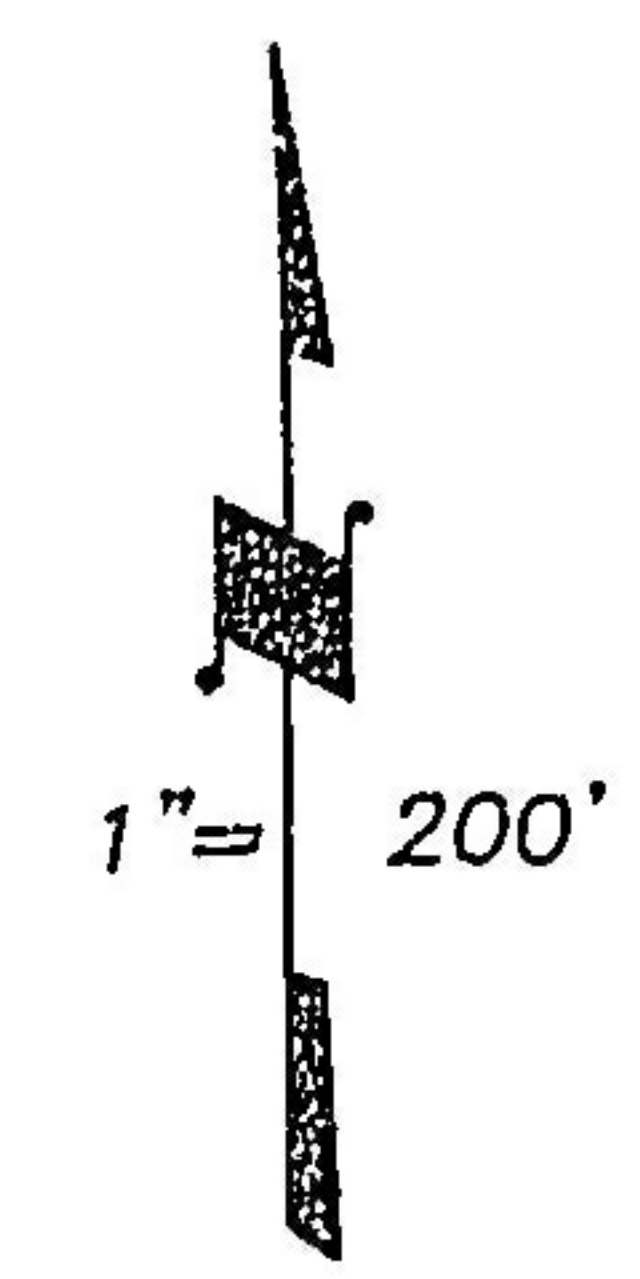

1.	NORTH	24.19'
2.	S75°20'E	50.00'
3.	N76°20'E	50.00'
4.	N63°50'E	125.52'
5.	N63°50'E	130.73'
6.	N69°35'E	95.58'
7.	S71°15'W	29.84'
8.	N78°40'W	74.70'
9.	N49°55'W	28.00'
10.	N83°25'W	37.20'
11.	S69°35'W	19.20'
12.	N80°46'46"E	3.21'
13.	N68°34'E	55.37'
14.	N60°16'E	54.38'
15.	N51°38'E	55.80'
16.	S40°W	27.00'
17.	S43°W	40.00'
18.	S3°W	22.00'
19.	S28°E	24.00'
20.	S71°30'E	40.00'
21.	S88°E	50.00'
22.	S50°E	40.00'
23.	S37°E	27.00'

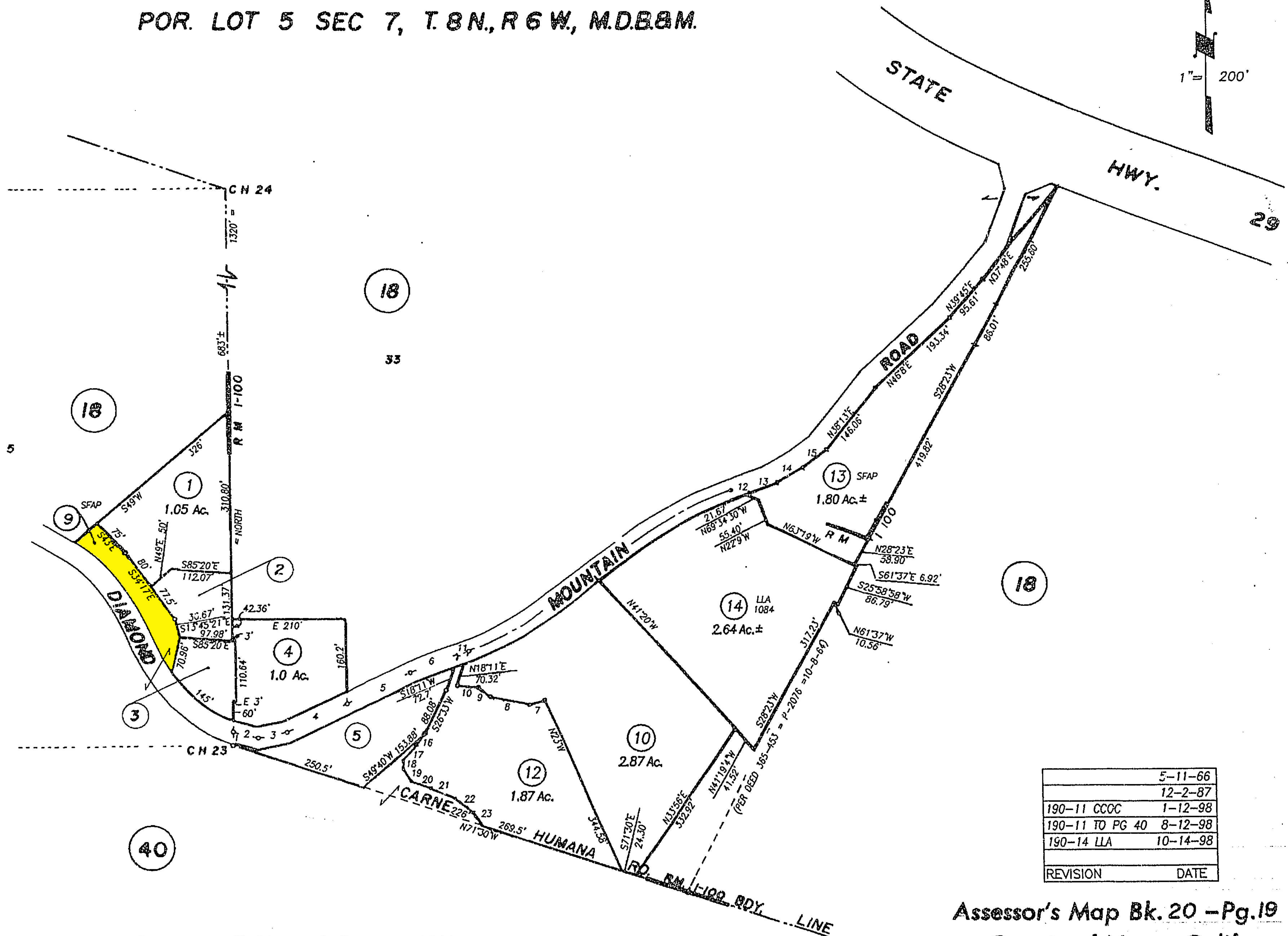

NOTE: This Map Was Prepared For Assessment Purposes Only, No Liability Is Assumed For The Accuracy Of The Data Delineated Hereon.

Carne Humana Rancho R.M. Bk. D Pat, Pg. 127  
Kilburn Homestead Tract R.M. Bk. I, Pg. 100

NOTE—Assessor's Block Numbers Shown in Ellipses  
Assessor's Parcel Numbers Shown in Circles.

	5-11-66
	12-2-87
190-11 CCOC	1-12-98
190-11 TO PG 40	8-12-98
190-14 LLA	10-14-98
REVISION	DATE

Assessor's Map Bk. 20 - Pg. 19  
County of Napa, Calif.